

# Two Axes Ultrasonic Anemometer HD52.3D...Series

## ○ ALL-IN-ONE COMPACT AND LIGHT

Wind Speed | Wind Direction | Wind Gust |  
Temperature | Relative Humidity | Barometric Pressure |  
Global Solar Radiation | Rainfall\*

## ○ HIGH SENSITIVITY

It can detect **very low speeds**, which are not  
detectable by traditional methods

## ○ MADE TO OPERATE UNDER ANY CONDITION

**Heating option** to prevent the accumulation of  
snow and ice and allow accurate measurements in all  
environmental conditions

## ○ ACCURATE AND RELIABLE SYSTEM

All instrument **sensors** are **factory-calibrated** and  
do not require additional interventions of the user

## ○ GREAT FLEXIBILITY

RS232, RS485, RS422 and SDI-12 serial interfaces  
are available with NMEA, MODBUS-RTU and SDI-12  
communication protocols

**Two analog output** for wind speed and direction or  
for velocity U-V cartesian components

## ○ FAST & EASY

Alignment facilitated by **built-in compass**

## ○ LOW POWER CONSUMPTION

Ideal for installation in **remote sites** -  
it can be powered  
by **photovoltaic panel** and **backup battery**



## Main Application Fields

Weather stations

Environmental Monitoring

Agriculture

Sports facility

Marine and Harbour applications

Airports

HVAC

Construction

Renewable energy

Building automation

## Technical Specification

### WIND SPEED

Sensor	Ultrasounds
Measuring range	0...60 m/s (0...50 m/s with rain gauge option)
Resolution	0.01 m/s
Accuracy	± 0.2 m/s or ± 2%, the greatest (0...35 m/s), ± 3% (> 35 m/s)

### WIND DIRECTION

Sensor	Ultrasounds
Measuring range	0...359.9°
Resolution	0.1°
Accuracy	± 2° RMSE from 1.0 m/s

### COMPASS

Sensor	Magnetic
Measuring range	0...360°
Resolution	0.1°
Accuracy	± 1°

### AIR TEMPERATURE (option 17)

Sensor	Pt100
Measuring range	-40...+70 °C
Resolution	0.1 °C
Accuracy	± 0.15 °C ± 0.1% of measurement

### RELATIVE HUMIDITY (option 17)

Sensor	Capacitive
Measuring range	0...100%RH
Resolution	0.1%
Accuracy (@ T = 15...35 °C)	± 1.5%RH (0...90%RH), ± 2%RH (remaining range)
Accuracy (@ T = -40...+70 °C)	± (1.5 + 1.5% of measurement ) % RH

### BAROMETRIC PRESSURE (option 4)

Sensor	Piezoresistive
Measuring range	300...1100 hPa
Resolution	0.1 hPa
Accuracy	± 0.5 hPa @ 20 °C

### SOLAR RADIATION (option P)

Sensor	Thermopile
Measuring range	0...2000 W/m <sup>2</sup>
Resolution	1 W/m <sup>2</sup>
Accuracy	2 <sup>nd</sup> Class Pyranometer

### RAINFALL (option T)

Sensor	Tipping bucket
Resolution	0.2 mm
Accuracy	99% up to 120 mm/h
Maximum rainfall rate	2000 mm/h
Collector area	127 cm <sup>2</sup>

## GENERAL FEATURES

Power Supply	10...30 Vdc
Power consumption	26 mA @ 24 Vdc without heater 8 W @ 24 Vdc with heater
Serial outputs	RS232, RS485 (¼ Unit Load), RS422 and SDI-12
Communication protocols	NMEA, MODBUS-RTU, SDI-12, proprietary RS232 and RS485
Analog outputs	2 analog outputs, for wind speed and direction. Output at choice among 4...20 mA (standard), 0...1 V, 0...5 V and 0...10 V (option 0...10 V needs 15...30 Vdc power supply)
Wind speed averaging interval	Configurable from 1 s to 10 min
Electrical connection	19-pole M23 male connector
Operating temperature	-40...+70 °C Minimum temperature for the rainfall sensor 1 °C
Protection degree	IP 66
Survival speed	90 m/s (60 m/s with rain gauge option)
Weight	About 1 kg (version HD52.3DP147) About 1.5 kg (version HD52.3DT147)
Case	Plastic material. Metal parts: AISI 316

## Dimensions

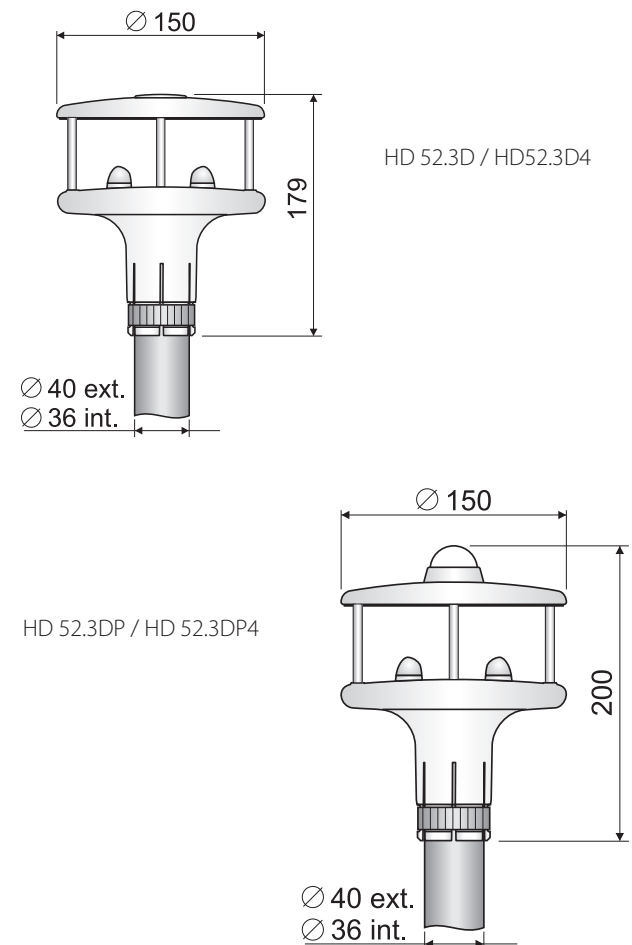

HD52.3DP17 /HD52.3DP147

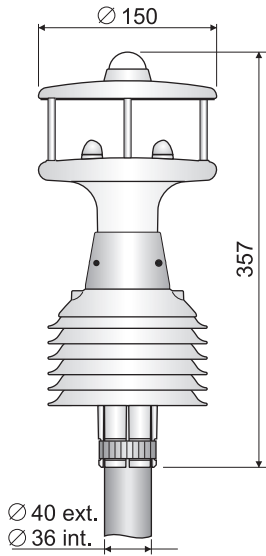

HD52.3D17 / HD52.3D147

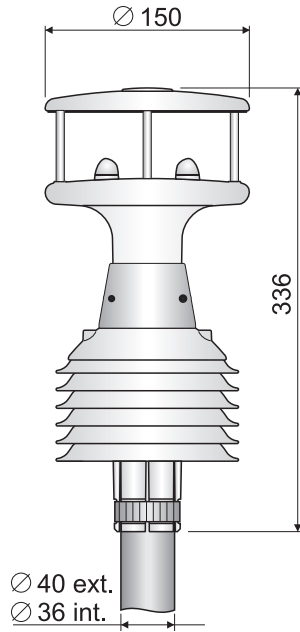

HD52.3DT147

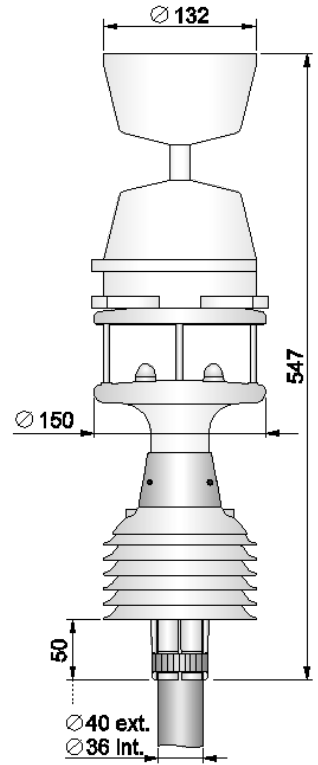

## Available Models

MODEL	WIND SPEED	WIND DIRECTION	RELATIVE HUMIDITY + TEMPERATURE	SOLAR RADIATION	RAINFALL	BAROMETRIC PRESSURE
HD52.3D	✓	✓				
HD52.3D4	✓	✓				✓
HD52.3DP	✓	✓		✓		
HD52.3DP4	✓	✓		✓		✓
HD52.3D17	✓	✓	✓			
HD52.3D147	✓	✓	✓			✓
HD52.3DP17	✓	✓	✓	✓		
HD52.3DP147	✓	✓	✓	✓		✓
HD52.3DT147	✓	✓	✓		✓	✓

All the models, except HD52.3DT147, are available with heating option (add R at the end of the code).

## PC Application Software

The PC software HD52.3D-S allows configuring the instrument, viewing the real time measurements both graphically and numerically, managing graphical presentation, printing and export in Excel® format of the data acquired with the Monitor function.

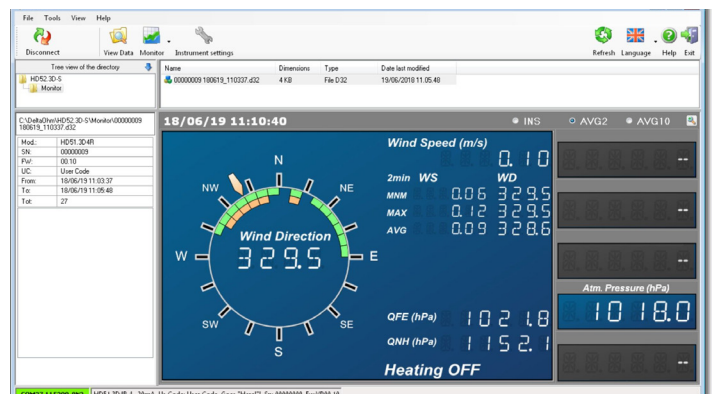

HD52.3D -S software: viewing the real time measurements

Two wind tunnels allow Calibration of most common anemometers. Both wind tunnel are Göttinger-Type, in order to assure the best metrological performance (stability, uniformity). Each Tunnel has LDA (Laser Doppler anemometer) in order to assure the best reference standard available.

Air speed calibration ranges include low range wind tunnel operating in the range 0.15 m/s, 35 m/s with a circular test section of 320 mm and a high range 1 m/s, 65 m/s with a circular test section of 600 mm.

Our primary standard, calibrated by the National Metrological Institute, guarantees the metrological traceability of our measurements.

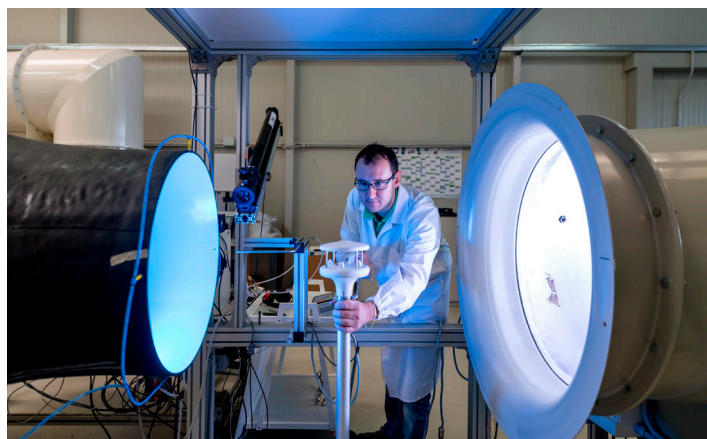

## Ordering Codes

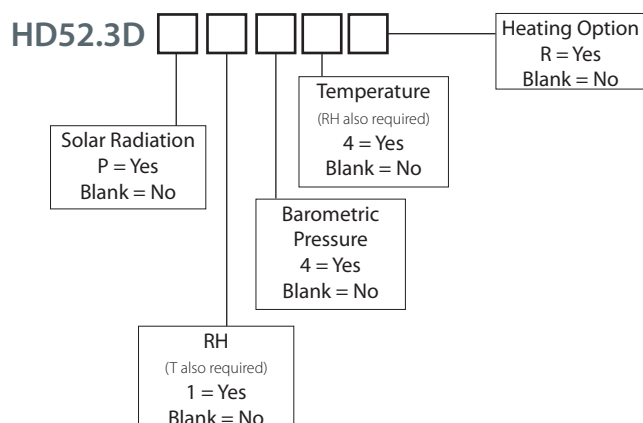

With **rain gauge**, the HD52.3DT147 model is available (measurement of wind speed and direction, rainfall, relative humidity, barometric pressure and temperature - no heater option).

**HD52.3D...**: 2-axis ultrasonic static anemometer for the measurement of wind speed and direction, U-V Cartesian components of wind speed, Wind Gust, relative humidity and temperature (optional), global solar radiation (optional), barometric pressure (optional) and rainfall (optional). **The "rainfall" and "global solar radiation" options are alternatives.** Equipped with compass. RS232, RS485, RS422 and SDI-12 serial outputs, NMEA, MODBUS-RTU and SDI-12 communication protocols. Two analog outputs, for wind speed and direction, factory-configurable within 4÷20 mA (standard), 0÷1 V, 0÷5 V or 0÷10 V (to be specified when ordering). Heater option available (except for version with rain gauge). Power supply: 10...30 Vdc (15...30 Vdc in case of 0÷10 V analog outputs). Installation on mast Ø 40 mm external and Ø 36 mm internal. Input with 19-pole M23 male connector and 19-pole M23 female free connector. Supplied with: **HD52.3D-S software** (downloadable from Delta OHM website) for instrument configuration and monitor, operating manual. On request, CP52...cable.

## Other versions:

**HD52.3DAC**: Version of the HD52.3D anemometer with only two 4÷20 mA analog outputs for wind speed and direction. 19-pole M23 connector. Available with heating option. It includes HD52.3D-S software downloadable from Delta OHM website. Supplied with female 19-pole M23 movable connector and operating manual. On request, CP52... cable.

**HD52.3DAF**: Version of the HD52.3D anemometer with two analog outputs: one frequency output, to simulate a cup anemometer, and one potentiometric output, to simulate a vane wind direction sensor. 19-pole M23 connector. Available with heating option. Supplied with female 19-pole M23 movable connector and operating manual. On request, CP52... cable.

## Accessories:

- RS52** Serial connection cable with built in USB/RS232 converter. USB connector for the PC and screw terminals on the instrument side.
- HD2005.20** Tripod with adjustable legs for installing environmental sensors. Material: anodized aluminum. Max. height 2 m. It can be fixed on a flat base with screws or to the ground with pegs. Foldable legs for the transport.
- HD2005.20.1** Tripod with adjustable legs for installing environmental sensors. Material: anodized aluminum. Max. height 3 m. It can be fixed on a flat base with screws or to the ground with pegs. Foldable legs for the transport.
- HD2004.22** Kit for fixing 1200 x 530 x 34 mm solar panel to Ø 40÷50 mm mast. AISI 304 stainless steel.
- HD2004.30** 80 W single crystal solar panel. Dimensions 1200 x 530 x 34 mm.
- CP52.x** 12 pole connecting cable with 19-pole M23 female free connector on one end, open wires on the other. Available lengths: 5 m., 10 m, 15 m, 20 m, 30 m, 50 m, 75m.
- CP52.C** Additional 19-pole M23 female free connector.



In order to ensure the quality of our instruments, we may have to develop our products. We may make changes or corrections at any time. Check on our website to make sure your documentation is up to date.

We look forward to your enquiry:  
Phone +39 049 897 7150  
Email: info@deltaohm.com

**Delta OHM S.r.l.**  
Single Member Company subject to direction and coordination of  
GHM MESSTECHNIK GmbH  
Via Marconi 5 | 35030 Caselle di Selvazzano (PD) | ITALY